

T1600 ULTRA

Redefined Speed.



Born from the race-proven DNA of our award-winning T1600, the T1600 ULTRA represents the absolute pinnacle of unrestricted aerodynamic performance. We threw away the rulebook to create a purebred speed machine engineered for riders who demand nothing less than maximum velocity, with zero compromises.

Every curve, every surface, every detail is designed to slice through air with ruthless efficiency. This is not a bike built for regulations. This is a bike built to win. To drop the competition. To set new personal bests. To make every watt count.



DESIGN PHILOSOPHY



ULTRA-THIN HEAD TUBE PROFILE

A razor-thin frontal area slices through headwinds like a fighter jet, minimizing drag and maximizing straight-line speed.

**D-TYPE INTAKE AERO SYSTEM
NEXT-GENERATION AERODYNAMICS**

At the core of the T1600 ULTRA lies our revolutionary D-Type Aero System, a breakthrough integration of head tube fairing and seat stay tailfin that creates a seamless airflow path over the entire frame. This patented design eliminates turbulence and drag at all yaw angles, delivering effortless high-speed cruising that leaves competitors in your wake.



WIDE-STANCE AERO FORK

The most significant evolution from the standard T1600. Our all-new wide-stance fork design drastically reduces turbulent airflow around the front wheel, delivering measurable aerodynamic gains while creating an aggressive, race-ready visual presence that commands attention.



**SHORTER CHAINSTAY
(RC) DESIGN**

A reduced chainstay length delivers more direct power transfer and snappier acceleration, giving you the edge in sprints and breakaways.



**T47 THREADED
BOTTOM BRACKET**

Features larger diameter bearings for exceptional durability and zero creaking. The threaded design ensures rock-solid reliability and maximum stiffness under the hardest sprint efforts.



**UNIVERSAL DERAILLEUR
HANGER (UDH)**

Reduces chain drop, improves shifting precision, and protects your frame and derailleur in the event of a crash. Easy to replace anywhere in the world, minimizing race-day downtime.



ULTRA-SLIM AERO SEATPOST

An exceptionally thin profile minimizes drag while also improving vertical compliance, delivering a smoother, more comfortable ride over long distances.

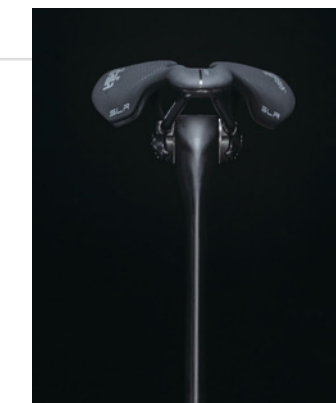

COLORS

Obsidian Gold



Nebula Green



T1600 ULTRA

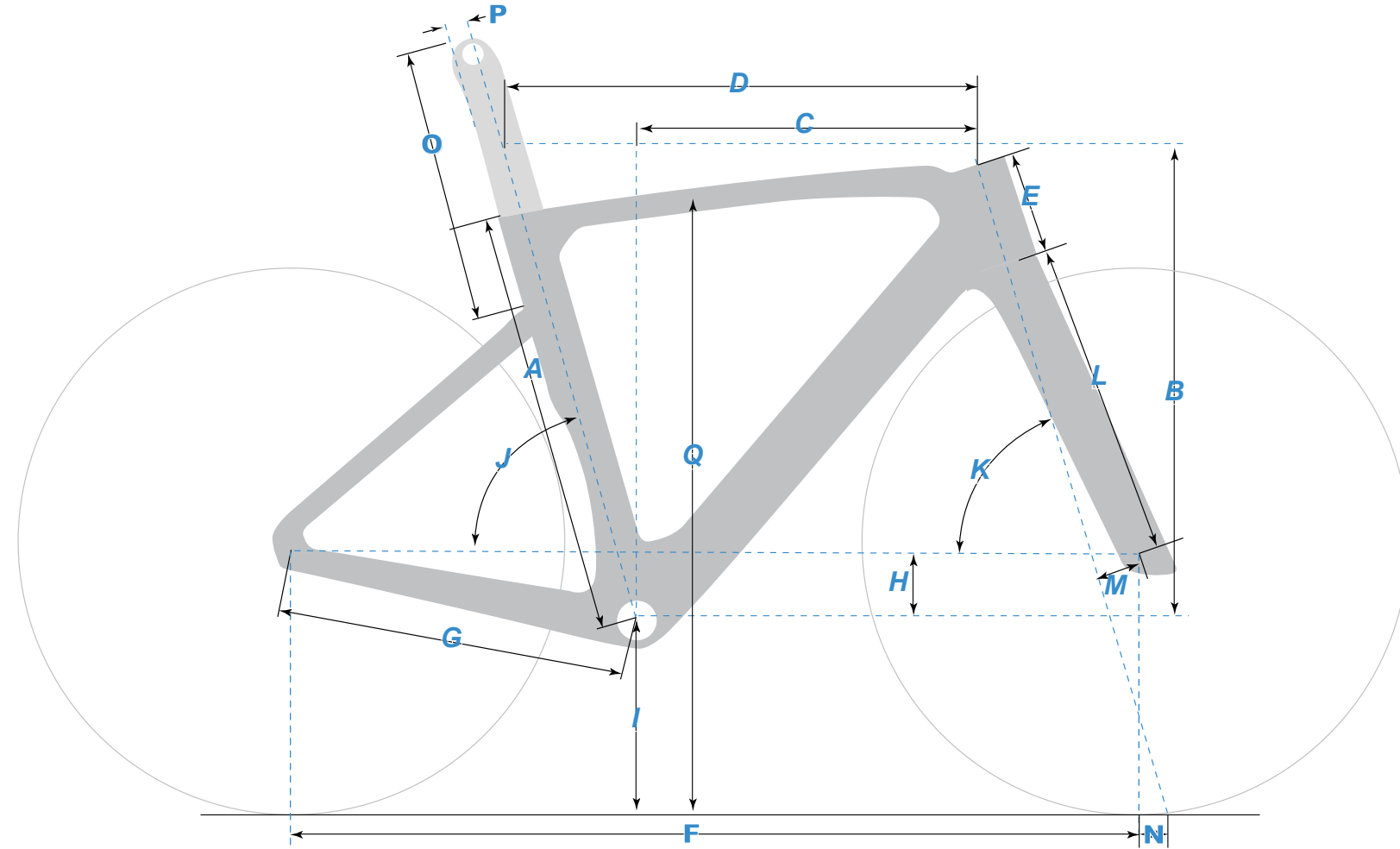

		XS	S	M	L	XL
A	Seat Tube Length	440	470	490	510	540
B	Stack	500	512	525	546	566
C	Reach	371	378	388	398	413
D	Top Tube Length	507	522	538	556	582
E	Head Tube Length	100	110	120	140	160
F	Wheelbase	967	971	975	987	1004
G	Chainstay Length	406	406	406	406	406
H	BB Drop	72	72	72	72	72
I	BB Height	271	271	271	271	271
J	Seat Tube Angle	74.8°	74.3°	74°	73.8°	73.4°
K	Head Tube Angle	70.7°	71.5°	72°	72.5°	72.9°
L	Fork Length	368	368	368	368	368
M	Fork Rake	50	50	44	44	44
N	Trail	62.5	57.9	61.4	58.5	56.2
O	Seatpost Length	320	320	360	360	360
P	Seatpost Setback	0	0	15	15	15
Q	Standover Height	734	756	768	791	813
R	STR	1.35	1.36	1.35	1.37	1.37
	Recommended Height CM	155~163	163~171	171~179	179~186	186~193

Selection of frame size is based on the measurement of the actual height of the span, height is supplemented, height is for reference only, it is recommended to collect FITTING data in order to make an accurate choice!