

TT5



Winspace TT5: UCI-Compliant Race-Ready Time Trial Machine
Engineered for Speed, Handmade for the Podium.

The TT5 is designed to deliver uncompromising speed and reliability for competitive riders across all UCI-sanctioned events and time trial races. It adheres strictly to UCI regulations while incorporating cutting-edge aerodynamic engineering and race-proven technology to give you the edge against the clock.

Whether you're competing in local time trials, national championships, or UCI-level events, the TT5 delivers the speed, rigidity, and flexible bike fitting to slice through the air and deliver racing winning performances.



DESIGN PHILOSOPHY

FEATURES

Winspace Cycling Co., Ltd // TT5

PRECISE SADDLE POSITIONING

Dial in your ultimate aero fit. The sliding saddle rail ensures millimeter-perfect positioning for maximum power output, comfort and aerodynamics.



ADJUSTABLE AEROBARS

Fully adjustable aerobars allow fine-tuning of height, reach, and angle to achieve the most efficient and comfortable riding position.



MAINTAIN HIGHER SPEEDS

The frame's aerodynamic shaping minimizes drag and helps you maintain higher speeds with less effort.



ULTRA-SLIM SEATPOST

Razor-thin profile. Lightning-fast look. Minimizes frontal area for maximum aero gain. A seamless blend of speed and ride feel.

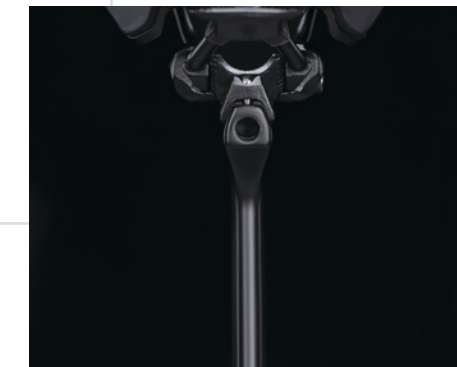

ENHANCED ACCELERATION AND MAXIMIZED POWER TRANSFER

The ultra-short chainstay enhances acceleration and maximizes power transfer for a more responsive ride.



Patented Closed Thru-Axle Fork Design

Streamlines the front end for cleaner airflow and improved aerodynamic efficiency.



Winspace Cycling Co., Ltd // TT5

TT5

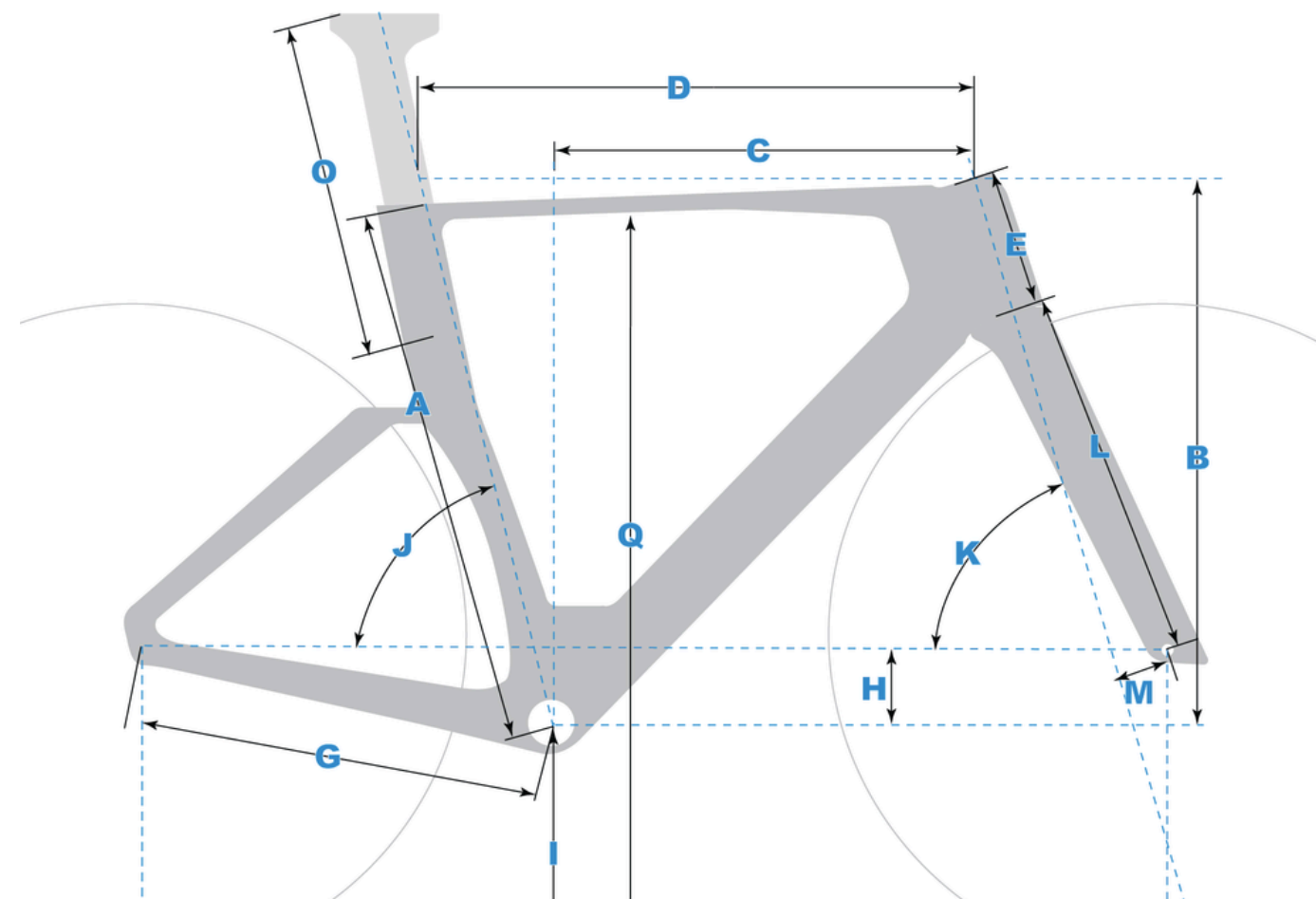

		XXS	XS	S	M	L	XL
A	Seat Tube Length	480	500	520	540	560	580
B	Stack	480	500	520	541	561	580
C	Reach	372	383	395	407	419	431
D	Top Tube Length	507	519	544	562	580	598
E	Head Tube Length	77	96	117	138	161	181
F	Wheelbase	967	982	997	1015	1030	1048
G	Chainstay Length	410	410	410	410	410	410
H	BB Drop	75	75	73	73	70	70
I	BB Height	273	273	273	273	273	273
J	Seat Tube Angle	74°	74°	74°	74°	74°	74°
K	Head Tube Angle	71°	71.5°	72°	72°	72.5°	72.5°
L	Fork Length	371	371	371	371	371	371
M	Fork Rake	50	50	50	50	50	50
N	Trail (45C)	64.2	61.2	58.2	58.2	55.3	55.3
O	Seatpost Length	400	400	400	400	400	400
Q	Standover Height	738	758	781	800	823	842
	Tire	700C*35C	700C*35C	700C*35C	700C*35C	700C*35C	700C*35C
	STR	1.290	1.305	1.316	1.329	1.339	1.346
	Recommended Height CM	155~163	163~170	170~178	178~185	185~193	193~200

Selection of frame size is based on the measurement of the actual height of the span, height is supplemented, height is for reference only, it is recommended to collect FITTING data in order to make an accurate choice!